

Reg. No. :

--	--	--	--	--	--	--	--	--	--	--	--	--	--	--	--	--	--	--	--

Question Paper Code : 70906

B.E./B.Tech. DEGREE EXAMINATIONS, NOVEMBER/DECEMBER 2023.

Sixth / Seventh Semester

Mechanical Engineering

ME 8691 — COMPUTER AIDED DESIGN AND MANUFACTURING

(Common to: Mechatronics Engineering)

(Regulations 2017)

Time : Three hours

Maximum : 100 marks

Answer ALL questions.

PART A — (10 × 2 = 20 marks)

1. How does the computer aided design system facilitate product design?
2. State the general transformation matrix.
3. Give any two advantages of parametric curves over other forms of curves.
4. "A B-spline curve is a more generalized form of Bezier curve". Comment on the statement.
5. What are the uses (any two) of graphical standards for data exchange?
6. How does OpenGL differ from GKS graphics standard?
7. Compare absolute positioning and incremental positioning in CNC operations.
8. List any four computer aided manufacturing packages.
9. What is part family?
10. What does one make an automated manufacturing system flexible?

PART B — (5 × 13 = 65 marks)

11. (a) List and describe various activities with an example involved in product development. Provide suitable diagrams wherever needed.

Or

- (b) With an example, elaborate on the steps involved in implementing CAM in a manufacturing industry.

12. (a) Consider the B-spline surface $Q(u, w)$ defined by the 4X4 polygon net;
- | | | | |
|------------------------|-----------------------|----------------------|-----------------------|
| $B_{1,1}[-15, 0, 15]$ | $B_{2,1}[-5, 5, 15]$ | $B_{3,1}[5, 5, 15]$ | $B_{4,1}[15, 0, 15]$ |
| $B_{1,2}[-15, 5, 5]$ | $B_{2,2}[-5, 10, 5]$ | $B_{3,2}[5, 10, 5]$ | $B_{4,2}[15, 5, 5]$ |
| $B_{1,3}[-15, 5, -5]$ | $B_{2,3}[-5, 10, -5]$ | $B_{3,3}[5, 10, -5]$ | $B_{4,3}[15, 5, -5]$ |
| $B_{1,4}[-15, 0, -15]$ | $B_{2,4}[-5, 5, -15]$ | $B_{3,4}[5, 5, -15]$ | $B_{4,4}[15, 0, -15]$ |
- Determine the surface point at the $P[U, V] = [0.5, 0.5]$.

Or

- (b) Discuss in detail about the basic elements and building operations of the CSG Scheme required to create the components shown in the figure. 1.

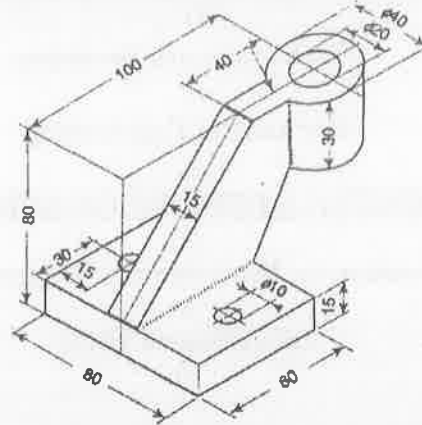

figure. 1

13. (a) Describe briefly the architecture of the following data exchange formats:
- (i) IGES (4)
 - (ii) STL (4)
 - (iii) CALS (5)

Or

- (b) Explain the various functionalities and applications of OpenGL.
14. (a) For the component shown in the figure. 2 make a CNC part program for a vertical machining centre to machine all the surfaces except the base and the hole of $\phi 6$ mm. Clearly show the set point and axes on the sketch of the part. Assume the available minimum machining allowance at all surfaces is 2 mm.

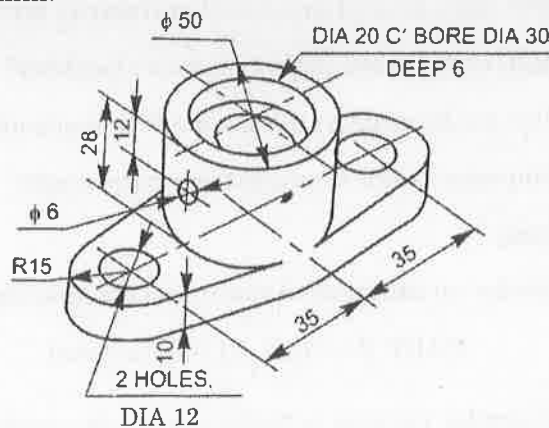

Figure. 2

Or

